

Scandia Sauna Heater Troubleshooting Guide

All service and repairs must be performed by certified personnel and must use Scandia certified components.

In order to effectively troubleshoot your Scandia Ultra Sauna heater, it is important to check the parameters of the installation first. Please check the below points and proceed based upon your answers. This guide should lead you to the exact problem of your heater and suggest the most efficient resolution to the problem. Check the following:

Fax Notes

- | | |
|---|--|
| <p>1. If the appropriate breaker in the circuit panel is in the on position.</p> <ul style="list-style-type: none"> - if no: turn it on. - If yes: check #2. | <p>1) breaker amp rating?</p> <hr/> |
| <p>2. Make sure the base of the heater is at least 10" from the floor of the sauna.</p> <ul style="list-style-type: none"> - if no: reposition the heater to the correct height. - If yes: check #3. | <p>2) distance from floor?</p> <hr/> |
| <p>3. When turning sauna on, with the timer on, turn thermostat on then off, make sure you hear the thermostat engaging the heating system (you will hear a click or clunk sound).</p> <ul style="list-style-type: none"> - if no: go to Thermostat Section - If yes: check #4. | <p>3) what sound is made?</p> <hr/> |
| <p>4. Heater guard-rail is not blocking airflow of the heater (at least 6" from out-vents)</p> <ul style="list-style-type: none"> - if no: realign heater guard-rail to appropriate parameters. - If yes: check #5. | <p>4) what is the distance ?</p> <hr/> |
| <p>5. Sauna room is vented with one intake vent located below the heater and one exhaust vent located on the other side of the room below the upper bench or at least knee high.</p> <ul style="list-style-type: none"> - if no: install appropriate venting - If yes: check #6. | <p>5) describe venting?</p> <hr/> |
| <p>6. Fuses in the fuse box are blown (for 15 and 18 KW versions only).</p> <ul style="list-style-type: none"> - if fuses are blown: replace appropriate fuses - If not: check #7. | <p>1) fuse amp rating?</p> <hr/> |
| <p>7. Check that each element is supplied by opposing phases (or leads). A heater element cannot be supplied by the same phase. This will destroy the element.</p> <ul style="list-style-type: none"> - if no: contact an electrician or the original installer to correct the wiring sequence immediately. <i>This condition can result in serious damage to your heater and possible fire hazard.</i> - If yes: Go to High-Limit Section | <p>1) describe phase sequence?</p> <hr/> |

High Limit Section

Please check all seven parameters on page one of this guide before proceeding to this section.

Prelude: The high-limit switch is located at the base of the sauna heater body. The red button protrudes from the bottom junction box. This red button resets the high-limit switch when tripped. The high-limit switch is a safety feature that shuts down your sauna when the timer and thermostat fails to shut down the heater. **If the high-limit switch is turning off your heater, this means your thermostat is not controlling the temperature as it should – or – the high-limit switch is turning off your heater prematurely (before the thermostat turns it off).**

Note: Before proceeding, make sure you have tested the thermostat as described in step #3 on the cover page.

If your high-limit switch is prematurely shutting down your heater, therefore not allowing your thermostat to regulate the heat, your high-limit sensor bulb must be adjusted. See below the instructions on how to adjust your high-limit sensor bulb.

Adjusting the High-Limit Switch Sensor Bulb

The sauna heater shell must be removed in order to adjust the high-limit switch sensor bulb.

1. It is not necessary to remove the heater from the wall.
2. Make sure breaker and/or all power sources are off/closed, and the heater is cool to the touch.
3. Remove the rocks from the pan.
4. Remove the four shell screws (two on each side located towards the back of the heater)
5. Lift the shell straight up and away from the wall, the shell will come off smoothly.
6. Proceed with the high-limit sensor bulb adjustment described below. **Warning: do not crimp/bend sensor bulb wire, this will disable the high-limit from working properly.**

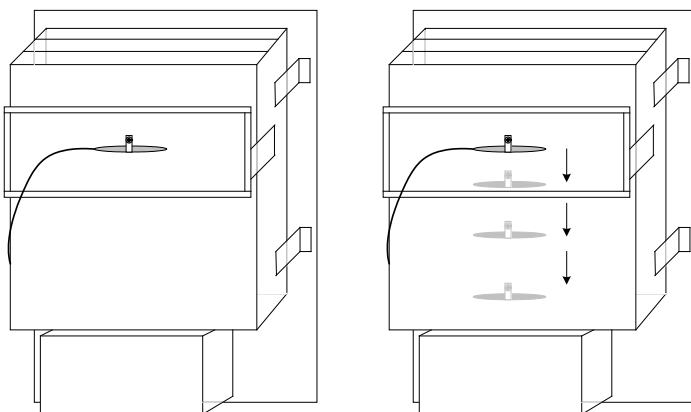

Factory high-limit
sensor location

High-limit sensor
adjustment locations

Depending on what temperature your high-limit switch is shutting down your sauna system, this will determine what location your high-limit sensor should be adjusted to. It is recommended that the sensor is moved downward in 2" increments. Each time, testing the sauna to see if the thermostat takes over control of the sauna (not the high-limit). **This test must be done with the shell on and rocks in place.** The sauna should reach 180 - 190 degrees at the #10 setting on the thermostat. The high-limit switch should shut the system down when the room's temperature reaches 220-240 degrees.

7. Replace shell and rocks until the adjustments meet the parameters described above and the thermostat is properly controlling the heater system.

Thermostat Section

Please check all seven parameters on page one of this guide before proceeding to this section.

Prelude: The thermostat can be located on the control panel outside of the sauna room or directly at the base of the sauna heater. The thermostat controls the temperature of the room. Because of varying room constructions, room sizes, materials, altitudes ... the thermostat works on a 1 to 10 basis rather than an actual temperature reading. The 10 setting on the temperature should be equivalent to 180 – 190 degrees Fahrenheit. If the sauna heater is being turned off (or controlled) by the high-limit (not thermostat), this **does not mean your thermostat is faulty**, it could be that your high-limit switch must be adjusted. If so, see **high-limit section** of this guide.

Thermostat Integrity Check – to check thermostat functionality: reset high-limit (only if tripped) and turn on sauna timer (if equipped with a 24 hour timer, make sure it is on). When the sauna heater is on, turn up and down the thermostat and determine at which number the thermostat engages the system (you will hear a click or clunk sound). Wait 10 minutes and check which number on the thermostat engages the system. If the number increases as the room gets warmer your thermostat is working properly.

When thermostat does not engage the sauna system:

- 1) check all seven parameters on page one of this guide.
- 2) check wires to make sure all connections to the thermostat, timer and contactors are snug.
 - If not – tighten all connections
 - If yes – check #3
- 3) Make sure thermostat copper capillary wires are not crimped or bent.
 - If crimped – thermostat must be replaced
 - If not crimped – check #4

Confirming a faulty thermostat – with the sauna off and all power connections shut off, bypass the thermostat by connecting the two thermostat lead wires from the controls together. Once done, restore power and turn on the timer. If the heater system turns on, this confirms your thermostat is faulty. **This is to be done for testing purposes only and by a licensed electrician.**

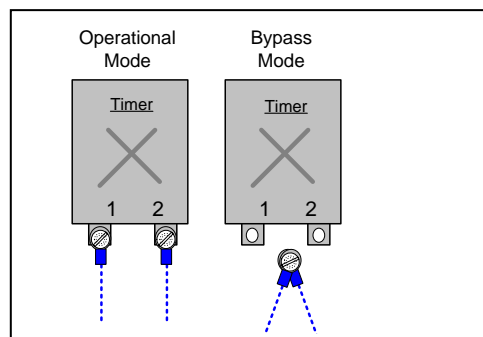

Timer Section

Prelude: The Scandia Ultra Sauna heater comes with two types of timers, a 60 minute timer or a 24 hour timer. The timer works in partnership with the thermostat. In order to operate the sauna heater, both the timer and thermostat must be turned on in order to activate the heater. When on the timer only allows the heater to be controlled by the thermostat. Said another way, the timer will not turn on the heater unless the thermostat is turned up. Inversely, the thermostat cannot turn on the sauna without the timer turned on. If the timer and the thermostat are turned on and the sauna does not turn on, **this does not mean that your timer is faulty.**

Timer Integrity Check – to check timer functionality: reset high-limit (only if tripped) and turn on sauna thermostat to #10 setting. (if equipped with a 24 hour timer, make sure it is off). Next, turn on the timer to see if it engages the system (you will hear a click or clunk sound).

When the timer does not engage the sauna system:

- 1) check all seven parameters on page one of this guide.
- 2) check wires to make sure all connections to the thermostat, timer and contactors are snug.
 - If not – tighten all connections
 - If yes – check #3
- 3) Make sure thermostat copper capillary wires are not crimped or bent.
 - If crimped – thermostat must be replaced
 - If not crimped – check #4

Confirming a faulty timer – with the sauna off and all power connections shut off, bypass the timer by connecting the two timer lead wires from the controls together. Once done, restore power and turn on the thermostat. If the heater system turns on, this confirms your timer is faulty. **This is to be done for testing purposes only and by a licensed electrician.**

